

# BUTTERFLY VALVE

## Series BFV ...

The butterfly valves of the series BFV are DVGW approved to the norms EN 161 and bear the **CE** - I D - Number. They are suitable to be used on residential and industrial combustion systems. They are particularly suitable for both manual and automatic control of gases belonging to the first, second and third family and of air. Installation between two flanges UNI PN10/PN16



### TECHNICAL FEATURES

Max. pressure	: 300 mbar	Body	: aluminium
Ambient temperature	: -10 ÷ +60 °C for gas -10 ÷ +80 °C for air	Stem	: stainless steel AISI 303
Control ratio	: 10:1	Butterfly disc	: aluminium
		Stem sealing	: "O" ring in perbunan - NBR

### FEATURES

- Sturdy, compact construction, especially suitable for industrial applications.
- Installation in any position.
- Mechanical position indicator.
- Lockable rotation angle from 0° to 90°.
- Without zero setting.
- External tightness by means of two "O" rings.
- Easy conversion on field from manual to automatic servicing.
- Wide range of accessories on request:
  - manual control lever
  - 1 or 2 internal reductions with respect to the nominal diameter of the valve
  - elliptic-shaped or moulded butterfly
  - VITON seals for air temperatures over 100°C
  - Butterfly disc AISI 304 for air temperature up to 200° C.

# BFV FLOW CHART

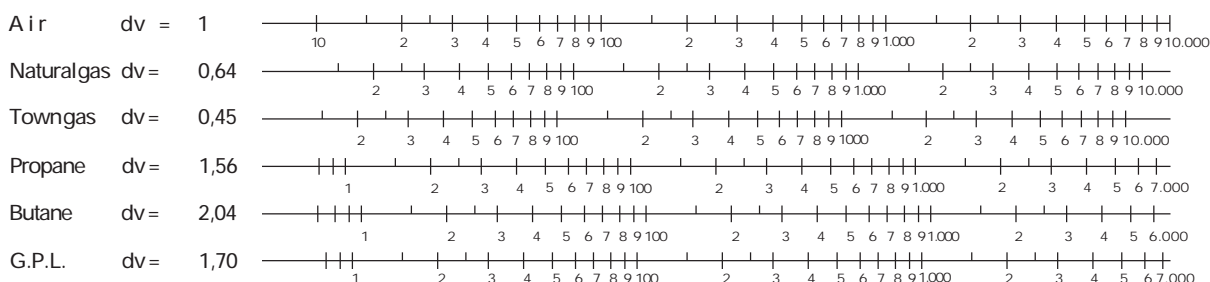
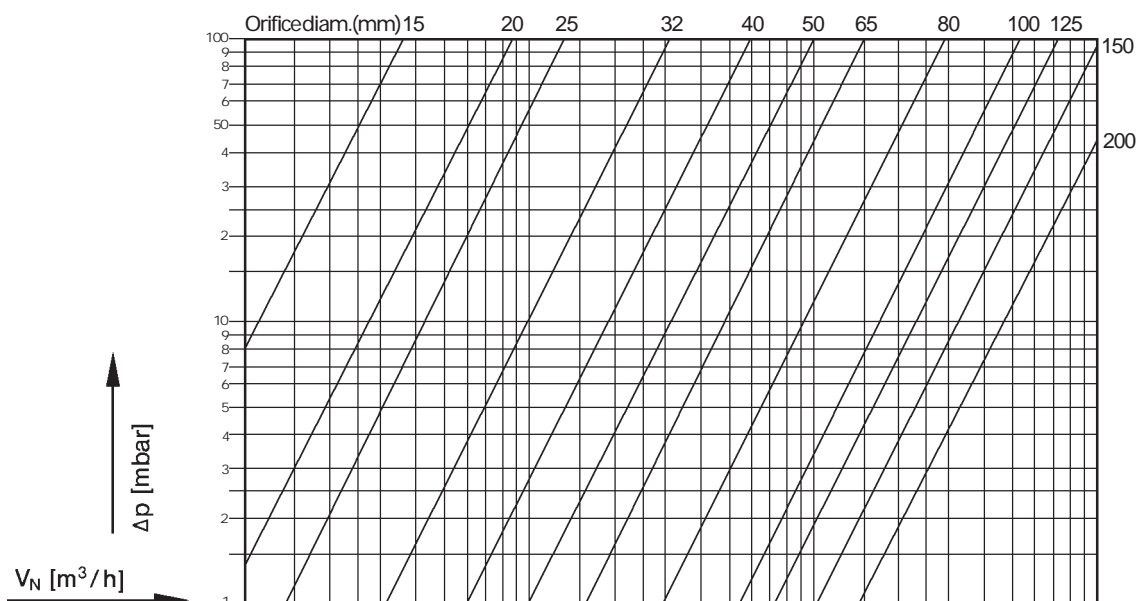

DN	orifice diameter (mm)	MODEL		DN	orifice diameter (mm)	MODEL	
		manual control	free shaft			manual control	free shaft
25	20	BFV25/20.A	BFV25/20.B	80	50	BFV80/50.A	BFV80/50.B
	25	BFV25.A	BFV25.B		65	BFV80/65.A	BFV80/65.B
					80	BFV80.A	BFV80.B
32	20	BFV32/20.A	BFV32/20.B	100	65	BFV100/65.A	BFV100/65.B
	25	BFV32/25.A	BFV32/25.B		80	BFV100/80.A	BFV100/80.B
	32	BFV32.A	BFV32.B		100	BFV100.A	BFV100.B
40	25	BFV40/25.A	BFV40/25.B	125	80	BFV125/80.A	BFV125/80.B
	32	BFV40/32.A	BFV40/32.B		100	BFV125/100.A	BFV125/100.B
	40	BFV40.A	BFV40.B		125	BFV125.A	BFV125.B
50	32	BFV50/32.A	BFV50/32.B	150	100	BFV150/100.A	BFV150/100.B
	40	BFV50/40.A	BFV50/40.B		125	BFV150/125.A	BFV150/125.B
	50	BFV50.A	BFV50.B		150	BFV150.A	BFV150.B
65	40	BFV65/40.A	BFV65/40.B	200	125	BFV200/125.A	BFV200/125.B
	50	BFV65/50.A	BFV65/50.B		150	BFV200/150.A	BFV200/150.B
	65	BFV65.A	BFV65.B		200	BFV200.A	BFV200.B

**Note:** for max. temperature 110°C add "1" after "B" in the model code. For max. temperature 200°C add "2" after "B" in the model code.

DIMENSIONS (mm)  
BFV... . A

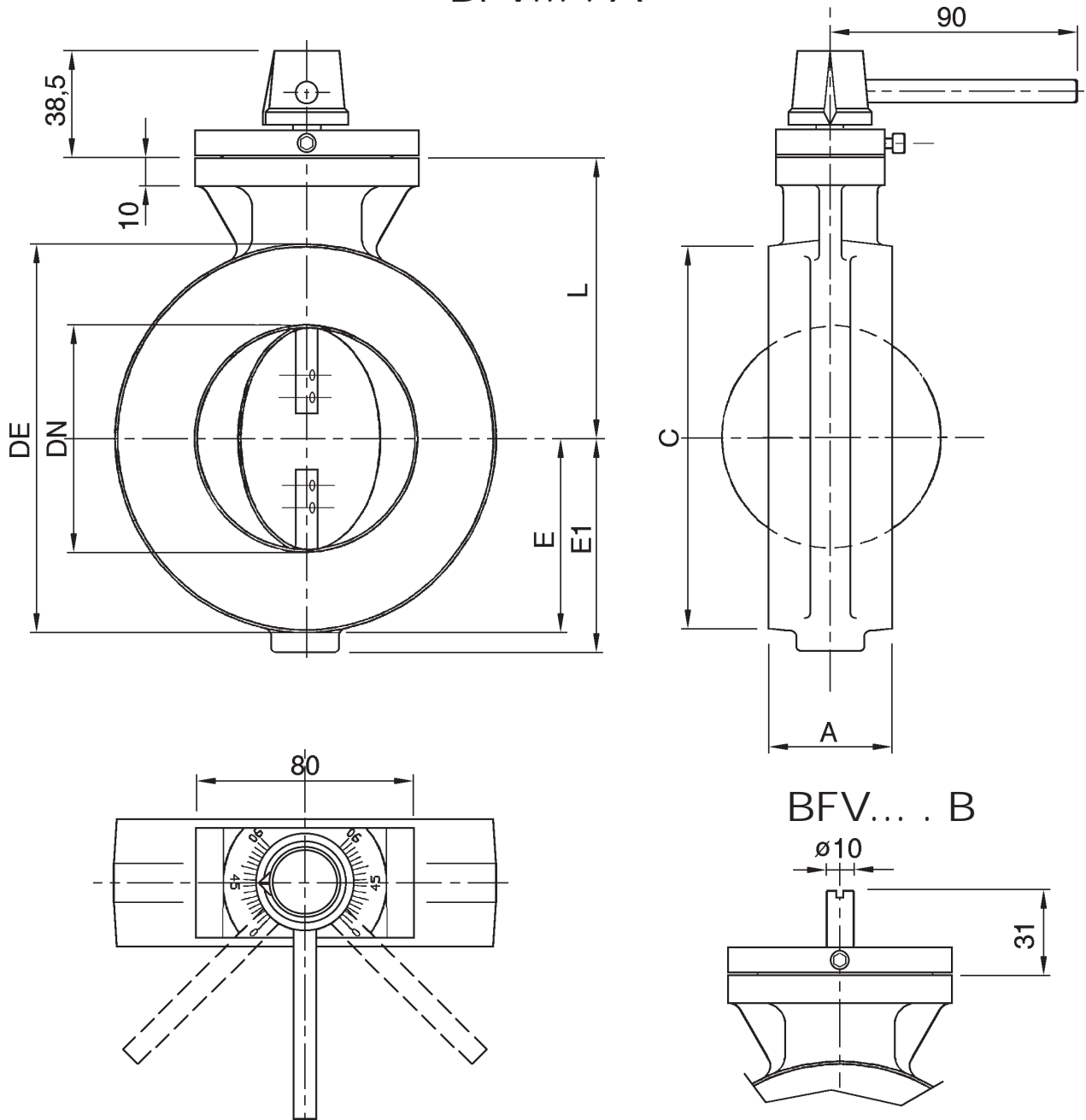

BFV... . B

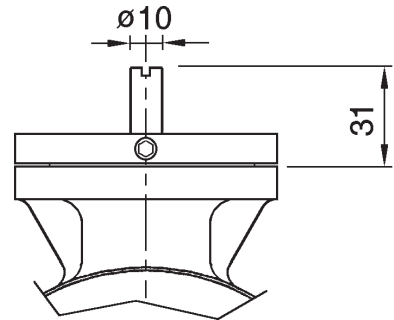

With control lever only from DN65 to DN200

<b>DN</b>	25	32	40	50	65	80	100	125	150	200
<b>DE</b>	71	82	92	107	126	141	162	192	217	272
<b>A</b>	40	40	40	43	46	46	52	56	56	60
<b>C</b>	68	78	88	102	122	138	158	188	212	268
<b>E</b>	35,5	41	46	54	/	/	/	/	/	/
<b>E1</b>	/	/	/	/	73	77	89	106	118	147
<b>L</b>	81,5	85	89,5	100,5	108	128	138	149,5	162	187
<b>Weight kg</b>	0,8	0,9	1,0	1,2	1,7	1,9	2,3	2,9	3,2	5

# INSTALLATION AND MAINTENANCE INSTRUCTIONS

## 1. **WARNING**

Installation, adjustment and maintenance of the valve must be carried out exclusively by skilled and authorized service technicians.

Non proper installation, adjustment, changes, use and maintenance may cause damages to the personnel or to the equipment. Consequently it is necessary to respect strictly the following instructions and local prescriptions for both the installation of electric devices, in case of motorized valves, and of gas systems.

## 2. **INSTALLATION**

- 2.1 Make sure that all operating data indicated on the valve plates correspond to those of the system.
- 2.2 When installing the valve be sure that there is sufficient clearance above the gear cover and that it can be easily accessible in order to perform manual servicing, automatic servicing by means of a gear motor or servicing by means of levers.
- 2.3 The installation of the BFV valves can be performed in any position but the position with horizontal axis is recommendable.
- 2.4 The valve can be installed in any location except where acid fumes or other deteriorating vapour may attack its metal parts or where gas leaks or explosive vapours are present in the atmosphere.
- 2.5 Do not use the valve as a lever.

## 3. **OPERATING**

- 3.1 Before operating the following points must be checked carefully:
  - Tightness of the external gas pipes.
  - That valve adjustment is performed within the requested angle range.
  - That mechanical locks or other retainers which may damage the valve have been removed.
- 3.2 Once these preliminary checks have been performed, the main gas tap can be opened and the operation test can be carried out.

## 4. **MAINTENANCE AND CHECKS**

- 4.1 The BFV valves do not require any particular current maintenance because they do not need lubrication.
- 4.2 It is recommendable to check at least once a year that the mechanical connections have not been modified, especially in case of systems which do not function vibration-free.

## 5. **REPLACEMENT**

In case replacement of the BFV valve is necessary, proceed as follows:

- 5.1 Close the main gas tap.
- 5.2 Remove the mechanical connections from the valve axis.
- 5.3 Remove the valve body from the inlet and outlet flanges by loosening the fastening screws from the respective nuts.
- 5.4 Install the new valve proceeding as per instructions reported in the foregoing chapters.

All the reported data are subject to be changed without notice.



Via F. De Sanctis, 53 - I - 20141 MILANO - Tel. +39 0289502912 - Fax. +39 028463084 - E-mail: econex@tin.it - www.econex.it